

Specifications

Operating Weight (Canopy/Cab)	7496 lb (3400 kg) / 7937 lb (3600 kg)
Ground Contact Pressure (Canopy/Cab)	4.5 psi (0.32 kgf/cm ²) / 4.7 psi (0.33 kgf/cm ²)
Engine Model	Yanmar 3TNV88
Output	24.4 hp (18.2 kw) / 2600 rpm
Displacement	100.2 cu.in (1.642L)
Pump capacity	28.6 gpm (108 L/min)
Auxiliary hydraulic flow	16.5 gpm (62.5 L/min)
Travel Motor	NACHI
Travel speed	1.7/2.6 mph (2.8/4.2 km/h)
Swing motor	NACHI
Swing speed	8.4 rpm
Fuel tank	10.6 gal (40 L)

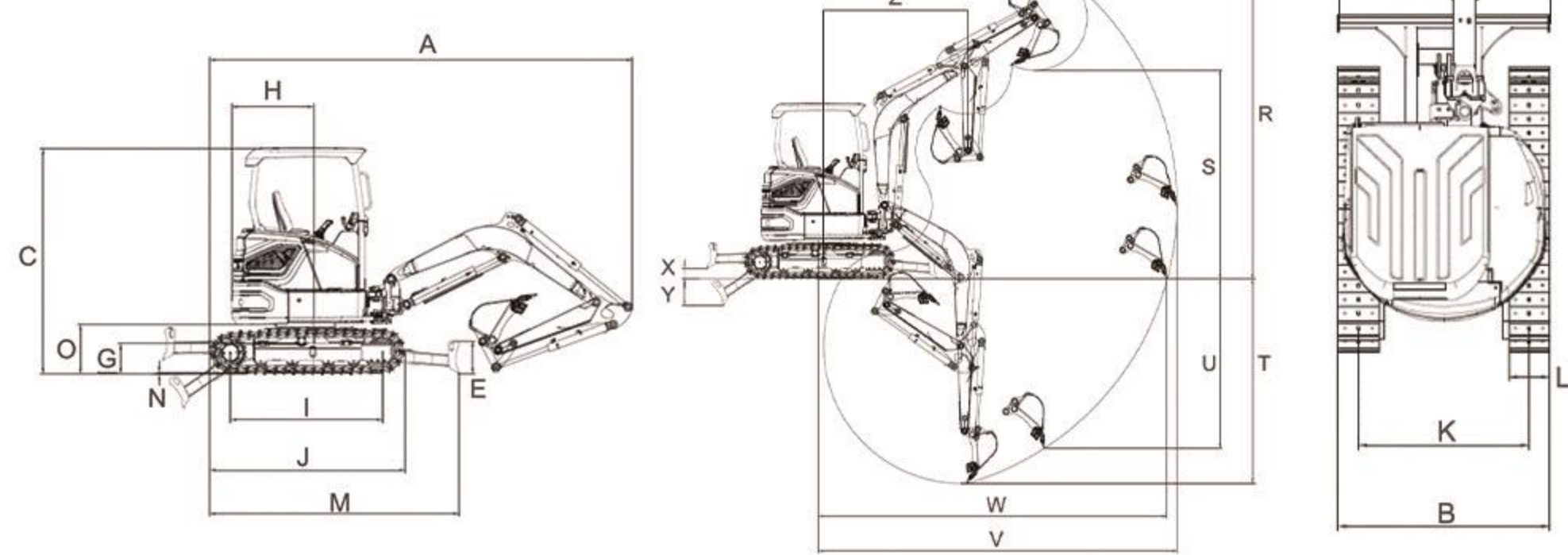

Overall Length	A	186 in (4730 mm)	Grouser Height	N	0.6 in (15mm)
Overall Width	B	67 in (1700 mm)	Upper Structure Ground Clearance	O	21.2 in (537mm)
Overall Height	C	94.5 in (2400 mm)	Swing System Offset Left	P	22.8 in (580 mm)
Dozer Blade Height	E	13.7 in (348 mm)	Swing System Offset Right	Q	25 in (637 mm)
Dozer Blade Width	F	67 in (1700 mm)	Max. Digging Height	R	190.5 in (4840 mm)
Min. Ground Clearance	G	11.8 in (300 mm)	Max. Dumping Height	S	134.8 in (3425 mm)
Min. Tail Turning Radius	H	33 in (850 mm)	Max. Dumping Depth	T	114.8 in (2915 mm)
Tumbler Distance	I	64 in (1620 mm)	Max. vertical Digging Depth	U	103.3 in (2625 mm)
Crawler Length	J	82.5 in (2094 mm)	Max. Digging Radius	V	205.7 in (5225 mm)
Track Gauge	K	55 in (1400mm)	Max. Digging Radius, At Ground Level	W	197.4 in (5015 mm)
Shoe Width	L	11.8 in (300 mm)	Dozer Blade Max. lift Above Ground	X	16 in (395 mm)
Ground Length	M	103in (2614.5mm)	Dozer Blade Max. Drop Below Ground	Y	17 in (425 mm)
			Min. Turning Radius	Z	86 in (2193 mm)

ARCPATH

AX35

EXCAVATOR

Rated Power
Operating Weigh

29.8hp (22.2kw)@2200rpm
7496 lb / 7937 lb



ARCPATH

AX35 EXCAVATOR

Reliability is non-negotiable for us, and the AX35 featuring its tailless design is no exception. Trusted by professional companies and occasional users alike, this machine is built with key components sourced from the world's top premium brands. From the Yanmar Tier 4 engine to the NACHI travel motor, every element is meticulously chosen for optimal reliability, durability, and enhanced performance.



Easy maintenance



The AX35 is designed for ease of maintenance, featuring wide-open panels for quick access to key components. Essential service points including the engine oil, starter motor, alternator, air filter, fuel and hydraulic tanks, and the main control valve are all conveniently within reach, simplifying upkeep and ensuring efficient operation.



Engine

Powered by the YANMAR Tier IV engine, the AX35 delivers an impressive 24.4 HP of rated power. Designed for peak reliability, it reduces vibration and ensures lasting durability. Effortlessly handling the toughest jobs, it's a powerhouse of efficiency and strength.

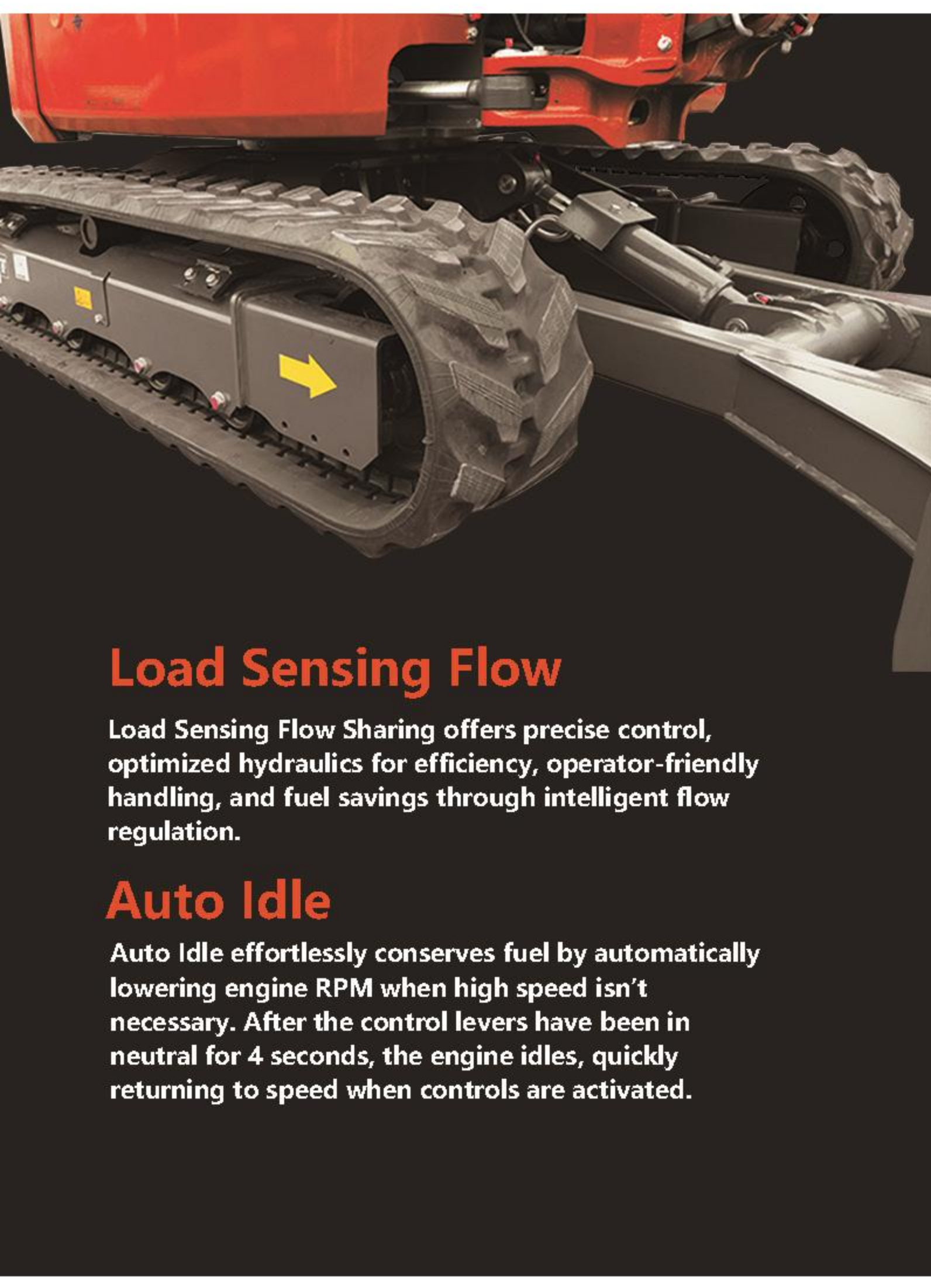

Load Sensing Flow

Load Sensing Flow Sharing offers precise control, optimized hydraulics for efficiency, operator-friendly handling, and fuel savings through intelligent flow regulation.

Auto Idle

Auto Idle effortlessly conserves fuel by automatically lowering engine RPM when high speed isn't necessary. After the control levers have been in neutral for 4 seconds, the engine idles, quickly returning to speed when controls are activated.



Auxiliary diverter

The auxiliary diverter control valve streamlines operation by allowing the attachment of a second hydraulic accessory without the need to disconnect the primary one.

Multi-function electronic joystick

The multi-function electronic joystick allows easy and precise control.



AX35 Cab

Tailless design

Tailless design perfect for narrow job sites. Enjoy a remarkable turning radius, ensuring exceptional maneuverability in tight spaces.



AX35

Attachments

Beyond standard features, our machine supports a range of attachments like grading buckets, hammers, rippers, clamps, augers, and quick couplers. Each is crafted to boost operational efficiency, offering a complete solution for diverse tasks.



AX35 EXCAVATOR